



## IMAGE®

19" MULTI-APPLICATION CABINET

# IMAGE®



## Technical specification

### DIMENSIONS

Internal Height	22U / 27U / 36U / 43U / 47U
Full Height	1078 / 1300 / 1700 / 2011 / 2189 mm
Depth	600 / 800 / 1000* / 1200* mm
Width	600 / 800 mm
Mounting depth	470 / 570 / 770* / 970* mm (panel mount - panel mount)
Load capacity	500 / 1000* Kg

\* Standard dimensions available for IMAGE® Server version

### FINISHING

External colour	 Anthracite RAL 7016 Cabinet frame, front door, rear panel and side panels	 Custom colours on demand
Internal colour	 Black RAL 9005 Panel mount supports and 19" panel mounting angle	

### MATERIALS SPECIFICATIONS

Frame	Steel 1.5 mm and 2.0 mm
Top and bottom covers	Steel 1.2 mm
Panel mounting angles and reducing channels	Steel 2.0 mm
Panel mount supports	Steel 1.5 mm
Side / rear panels	Steel 1.0 mm
Doors	Steel or Metal trim steel 1.0 mm
Glass	Tempered 4.0 mm UNI EN1250.1

### STANDARDS

IEC 60297	Dimension of mechanical structures of the 19" equipment
DIN 41494	Basic specification for 19" construction systems
EN 60950	European safety standards for information technology equipment
VDE0100	Installation and set-up of current system and grounding
DIN-1249-11	Glass building; glass edges

### INTRODUCTION TO IMAGE®

IMAGE® is a versatile cabinet for multi-applications installation. The cabinet frame consists of 2 vertical steel welded frames and top/bottom covers that guarantee a maximum load rate of 500Kg uniformly distributed. The side panels, easily removable, are provided with external locks and a system that protects from accidental fall during their removal. The 19" panel mounting angles are fixed through side panel mount supports that allow adjustable positioning in the depth of the cabinet and can be adapted to most of the 19" equipment on the market. The doors, in their available options, are equipped with single central key lock, reversible opening and can be equipped with a swing handle. Manual or automatic keyed alike locks are available on request. The top cover is designed to fix "zero U" ventilation fan tray with 2 or 4 fans (optional).

### KEY FEATURES

- Cabinet frame formed by 2 vertical frames, top and bottom cover
- Side vented top cover provided with 2 cable entry areas with cover plate or alternatively allowing the fixing of 2 or 4 "zero U" fans fan tray
- Adjustable 19" panel mounting angles at the front, compliant to IEC60297 norms (optional at the rear)
- Side reducing cable channel for 19" (800 mm cabinet width) with vertical cable management designed to support cable management accessories
- Easily removable side panels with security external locks
- Reversible opening glass metal trim front door, removable rear panel. Glass vented on metal trim and rear metal door, single or double, plain or vented as optional
- Open bottom for an easy entry of the cables or allowing to mount gland plates
- Adjustable feet
- Castors with 80 Kg or 115 Kg load rate as optional
- Static load rate of 500 Kg uniformly distributed
- Additional bay version settled for bayed cabinets
- Designed to mount the earth continuity kit according to EN60950 norms



IMAGE® - Front glass door

# IMAGE®

## Technical specifications

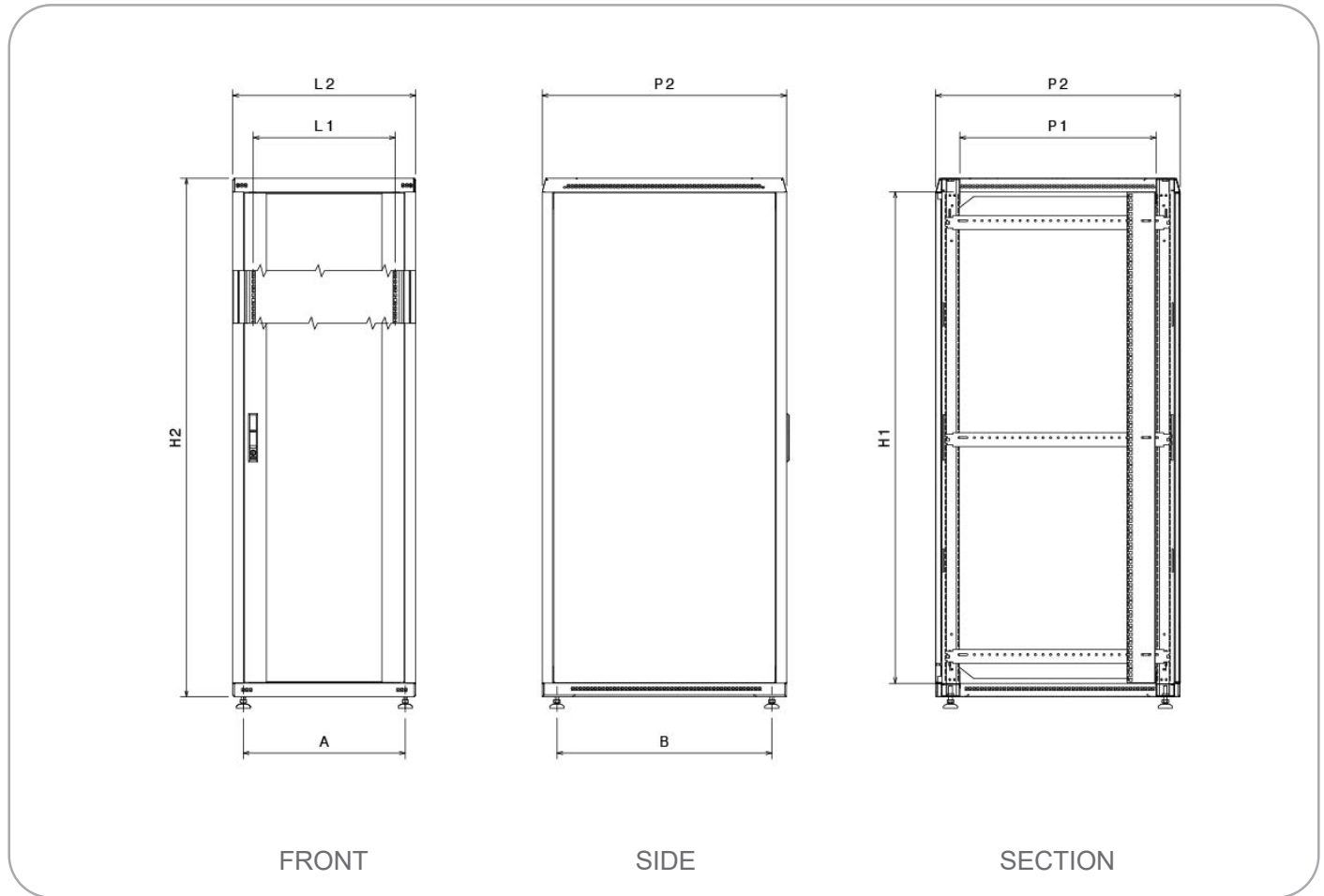

Rack Dimensions	Height		Width		Depth		Feet position	
	H1	H2 (mm)	L1	L2 (mm)	P1 (mm)	P2 (mm)	A (mm)	B (mm)
22U 600 x 600	22U	1078	19"	600	447	600	531	504
22U 600 x 800	22U	1078	19"	600	647	800	531	704
22U 800 x 600	22U	1078	19"	800	447	600	731	504
22U 800 x 800	22U	1078	19"	800	647	800	731	704
27U 600 x 600	27U	1300	19"	600	447	600	531	504
27U 600 x 800	27U	1300	19"	600	647	800	531	704
27U 800 x 600	27U	1300	19"	800	447	600	731	504
27U 800 x 800	27U	1300	19"	800	647	800	731	704
36U 600 x 600	36U	1700	19"	600	447	600	531	504
36U 600 x 800	36U	1700	19"	600	647	800	531	704
36U 800 x 600	36U	1700	19"	800	447	600	731	504
36U 800 x 800	36U	1700	19"	800	647	800	731	704
43U 600 x 600	43U	2011	19"	600	447	600	531	504
43U 600 x 800	43U	2011	19"	600	647	800	531	704
43U 800 x 600	43U	2011	19"	800	447	600	731	504
43U 800 x 800	43U	2011	19"	800	647	800	731	704
47U 600 x 600	47U	2189	19"	600	447	600	531	504
47U 600 x 800	47U	2189	19"	600	647	800	531	704
47U 800 x 600	47U	2189	19"	800	447	600	731	504
47U 800 x 800	47U	2189	19"	800	647	800	731	704

### Additional heights to full height H2:

- Adjustable feet: Minimum 25 mm - Maximum 40 mm
- Castors - 80 Kg static load: 75 mm
- Castors - 115 Kg static load: 115 mm



# IMAGE® Open Frame Primary cabinet

## “PRIMARY” CABINET READY TO USE

IMAGE® Open Frame Primary Kit is a versatile cabinet for multi-applications installation. The structure is formed by 2 vertical welded frame and top/bottom covers. Made of sheet steel to guaranty a maximum of static load rate of 500 Kg evenly distributed. The 19” panel mounting angles are fixed through the side panel mount supports that allow adjustable positioning in the depth of the cabinet and can be adapted to most of the 19” standard equipment. The frame is equipped with height-adjustable feet, optionally with brake or unbraked castors.

## CONTENTS OF KIT

Description	Qty
Open frame	1
19” Panel mounting angles at front	1 pair
19” reducing cable channel at front (800 mm cabinet width)	1 pair
Panel mount support for 36U cabinet	3 pairs
Panel mount support for 43U cabinet	4 pairs
Panel mount support for 47U cabinet	4 pairs
Top panels	1 pair
Adjustable feet	1 kit

## ORDERING INFORMATION

Height	W x D	W x D
	600 x 600 mm	600 x 800 mm
36U	<a href="#">VT385-776482</a>	<a href="#">VT385-776485</a>
43U	<a href="#">VT385-776483</a>	<a href="#">VT385-776486</a>
47U	<a href="#">VT385-776484</a>	<a href="#">VT385-776487</a>

Height	W x D	W x D
	800 x 600 mm	800 x 800 mm
36U	<a href="#">VT385-776488</a>	<a href="#">VT385-776491</a>
43U	<a href="#">VT385-776489</a>	<a href="#">VT385-776492</a>
47U	<a href="#">VT385-776490</a>	<a href="#">VT385-776493</a>

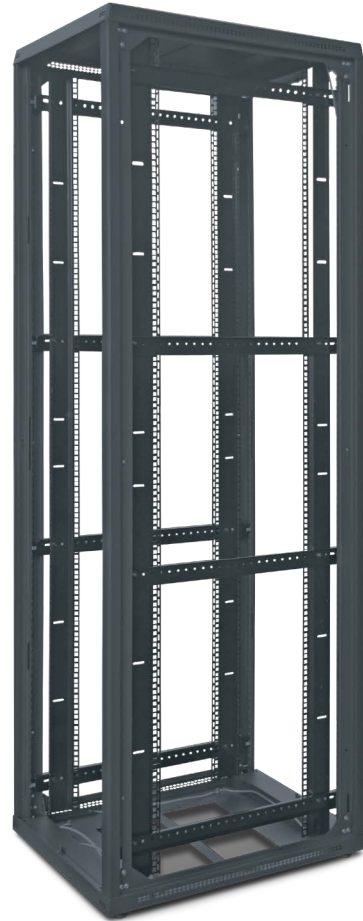

IMAGE® Open Frame  
600x800 mm  
Front and rear 19”  
panel mounting angles evolution

# IMAGE® Primary cabinet

## “PRIMARY” CABINET READY TO USE

The IMAGE® Primary cabinet is a ready configured enclosure, pre-equipped with 1 lockable door, a removable rear panel, 2 side panels, top gland plates, front 19” panel mounting angles, panel mount supports and adjustable feet. It can also be used as the starting point for creating a unique enclosure, by adding additional accessories.

The IMAGE® Additional Bay is a ready configured enclosure without side panels but including the baying kit.

## CONTENTS OF KIT

Description	Qty
Open frame	1
Glass / metal front door with lock	1
Removable rear panel	1
Removable side panels	2
Top half cover for plate	2
19” Panel mounting angles at front	1 pair
19” reducing cable channel at front (800 mm cabinet width)	1 pair
27U Panel mount support	2 pairs
36U Panel mount support	3 pairs
43U Panel mount support	4 pairs
47U Panel mount support	4 pairs
Adjustable feet	1 kit

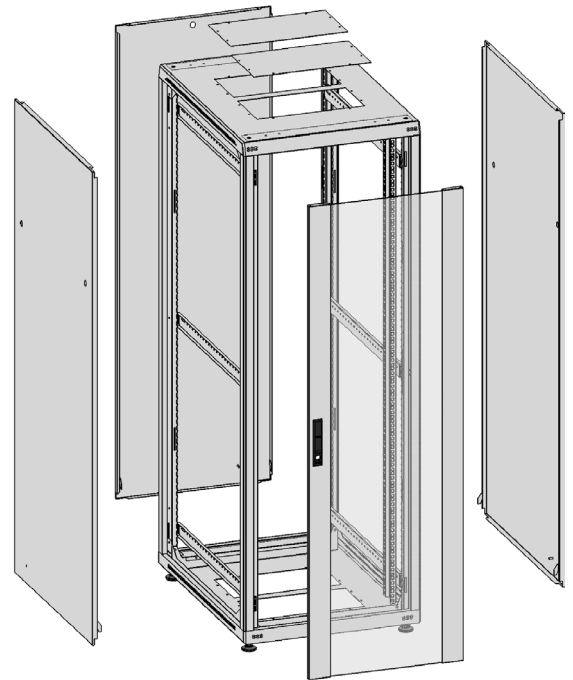

IMAGE® PRIMARY CABINET  
600 mm deep

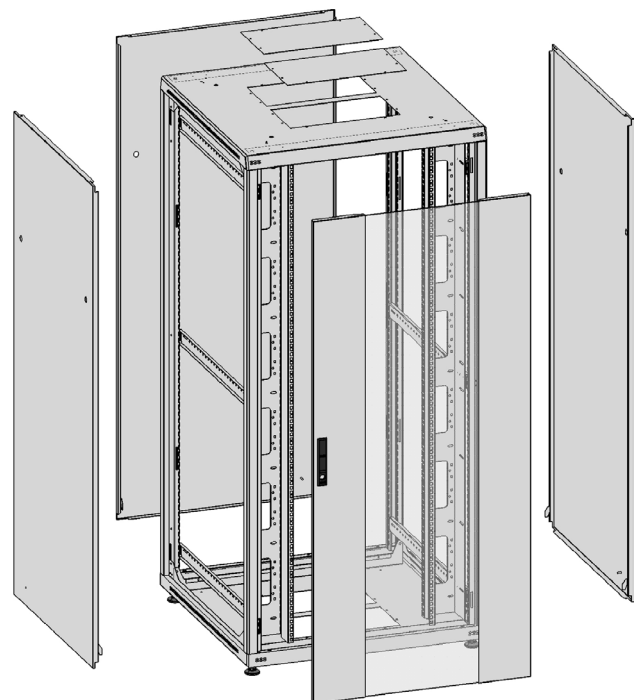

IMAGE® PRIMARY CABINET  
800 mm deep

### FRAME

The frame includes 4 verticals and 2 end frames.

### PANEL MOUNTING ANGLES

IMAGE<sup>®</sup> is supplied with 2, 19" panel mounting angles at front.

### SIDE PANELS

Side panels are supplied with external quarter turn locking, as option it is possible to order a traditional keylock. Side panels are provided of a system that protect from accidental fall during their removal (safety).

### FRONT AND REAR CLOSING

Closing options:

#### Front closing

- Glass door (standard) with a single closing point, keyed lock.
- Glass door with metal frame / three point locking, swing handle and European keyed lock cilinder.
- Double glass door with metal frame, single closing point, keyed lock.
- Metal door / single closing point or three point locking, swing handle and European keyed lock cilinder.
- Metal vented door / single closing point or three point locking, swing handle and European keyed lock.

#### Rear closing

- Removable Panel (standard) triangular key locks supplied.
- Metal single door / single closing point or three point locking, swing handle and European keyed lock cilinder.
- Metal double door / single point central locking.
- Metal vented door / single closing point or three point locking, swing handle and European keyed lock cilinder.
- Metal vented double door / single point central locking.

### SWING HANDLE

Standard doors, with a single closing point, are provided of keyed lock and do not have the swing handle.

For standard doors, both glass and metal, can be ordered, as option, the swing handle with single point central locking. As a further option can be required a European keyed lock cilinder, automatic or manual.

### VENTED TOP COVER

This top allows convected air to flow out through the sides of the top and is provided with two cable entries with panels. The same top cover can host a thermal kit with two fans, still allowing space for cable entries.

### LIFTING EYES

Lifting eyes are sold as a kit of 4 and can be fitted on the upper corners to lift up the cabinet in an easy way. Each lifting eye has a load capacity of 320 Kg.

### BOTTOM

The bottom is open to offer maximum space for comfortable cable passage.

### CASTORS KIT

Castors can load up to 115 Kg each under average conditions; fitted to the rack trough the treated holes at the bottom instead of the adjustable feet. Optionally available a plinth to mount feet and castors at the same time.



Frame

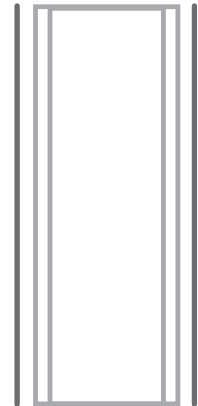

Side panels



Metal door



Glazed door



Bottom



Top cover

# IMAGE®

## Ordering informations

### IMAGE® PRIMARY KIT GLASS FRONT DOOR METAL REAR PANEL

Description	H	W x D	
		600 x 600 mm	600 x 800 mm
Primary Enclosure	22U	<a href="#">VT386-777417</a>	<a href="#">VT386-777418</a>
Primary Enclosure	27U	<a href="#">VT384-775335</a>	<a href="#">VT384-775341</a>
Additional bay	27U	<a href="#">VT386-775685</a>	<a href="#">VT386-775688</a>
Primary Enclosure	36U	<a href="#">VT384-775336</a>	<a href="#">VT384-775342</a>
Additional bay	36U	<a href="#">VT386-775686</a>	<a href="#">VT386-775689</a>
Primary Enclosure	43U	<a href="#">VT384-775337</a>	<a href="#">VT384-775343</a>
Additional bay	43U	<a href="#">VT386-775687</a>	<a href="#">VT386-775690</a>
Primary Enclosure	47U	<a href="#">VT384-775734</a>	<a href="#">VT384-775735</a>
Additional bay	47U	<a href="#">VT386-776002</a>	<a href="#">VT386-776003</a>

Description	H	800 x 600 mm		800 x 800 mm	
Primary Enclosure	22U	<a href="#">VT386-777419</a>	<a href="#">VT386-777420</a>		
Primary Enclosure	27U	<a href="#">VT384-775344</a>	<a href="#">VT384-775347</a>		
Additional bay	27U	<a href="#">VT386-775691</a>	<a href="#">VT386-775694</a>		
Primary Enclosure	36U	<a href="#">VT384-775345</a>	<a href="#">VT384-775348</a>		
Additional bay	36U	<a href="#">VT386-775692</a>	<a href="#">VT386-775695</a>		
Primary Enclosure	43U	<a href="#">VT384-775346</a>	<a href="#">VT384-775349</a>		
Additional bay	43U	<a href="#">VT386-775693</a>	<a href="#">VT386-775696</a>		
Primary Enclosure	47U	<a href="#">VT384-775736</a>	<a href="#">VT384-775737</a>		
Additional bay	47U	<a href="#">VT386-776004</a>	<a href="#">VT386-776005</a>		



IMAGE® - Primary Kit  
600 mm width

### IMAGE® PRIMARY KIT METAL FRONT DOOR METAL REAR PANEL

Description	H	W x D	
		600 x 600 mm	600 x 800 mm
Primary Enclosure	22U	<a href="#">VT386-777421</a>	<a href="#">VT386-777422</a>
Primary Enclosure	27U	<a href="#">VT386-775673</a>	<a href="#">VT386-775676</a>
Additional bay	27U	<a href="#">VT386-775697</a>	<a href="#">VT386-775700</a>
Primary Enclosure	36U	<a href="#">VT386-775674</a>	<a href="#">VT386-775677</a>
Additional bay	36U	<a href="#">VT386-775698</a>	<a href="#">VT386-775701</a>
Primary Enclosure	43U	<a href="#">VT386-775675</a>	<a href="#">VT386-775678</a>
Additional bay	43U	<a href="#">VT386-775699</a>	<a href="#">VT386-775702</a>
Primary Enclosure	47U	<a href="#">VT386-775989</a>	<a href="#">VT386-775990</a>
Additional bay	47U	<a href="#">VT386-775997</a>	<a href="#">VT386-775998</a>

Description	H	800 x 600 mm		800 x 800 mm	
Primary Enclosure	22U	<a href="#">VT386-777423</a>	<a href="#">VT386-777424</a>		
Primary Enclosure	27U	<a href="#">VT386-775679</a>	<a href="#">VT386-775682</a>		
Additional bay	27U	<a href="#">VT386-775703</a>	<a href="#">VT386-775706</a>		
Primary Enclosure	36U	<a href="#">VT386-775680</a>	<a href="#">VT386-775683</a>		
Additional bay	36U	<a href="#">VT386-775704</a>	<a href="#">VT386-775707</a>		
Primary Enclosure	43U	<a href="#">VT386-775681</a>	<a href="#">VT386-775684</a>		
Additional bay	43U	<a href="#">VT386-775705</a>	<a href="#">VT386-775708</a>		
Primary Enclosure	47U	<a href="#">VT386-775991</a>	<a href="#">VT386-775992</a>		
Additional bay	47U	<a href="#">VT386-775999</a>	<a href="#">VT386-776001</a>		



IMAGE® - Primary Kit  
600 mm width

# IMAGE®

## Ordering informations

### IMAGE® PRIMARY GLASS FRONT DOOR METAL REAR DOOR

Description	H	W x D	
		600 x 600 mm	600 x 800 mm
Primary Enclosure	22U	<a href="#">VT386-777425</a>	<a href="#">VT386-777426</a>
Primary Enclosure	27U	<a href="#">VT386-777429</a>	<a href="#">VT386-777430</a>
Additional bay	27U	on request	on request
Primary Enclosure	36U	<a href="#">VT386-777433</a>	<a href="#">VT386-777434</a>
Additional bay	36U	on request	on request
Primary Enclosure	43U	<a href="#">VT386-777405</a>	<a href="#">VT386-777406</a>
Additional bay	43U	on request	on request
Primary Enclosure	47U	<a href="#">VT386-777409</a>	<a href="#">VT386-777410</a>
Additional bay	47U	on request	on request

Description	H	800 x 600 mm	
		800 x 600 mm	800 x 800 mm
Primary Enclosure	22U	<a href="#">VT386-777427</a>	<a href="#">VT386-777428</a>
Primary Enclosure	27U	<a href="#">VT386-777431</a>	<a href="#">VT386-777432</a>
Additional bay	27U	on request	on request
Primary Enclosure	36U	<a href="#">VT386-777435</a>	<a href="#">VT386-777436</a>
Additional bay	36U	on request	on request
Primary Enclosure	43U	<a href="#">VT386-777407</a>	<a href="#">VT386-777408</a>
Additional bay	43U	on request	on request
Primary Enclosure	47U	<a href="#">VT386-777411</a>	<a href="#">VT386-777412</a>
Additional bay	47U	on request	on request



IMAGE® - Primary Kit  
600 mm width

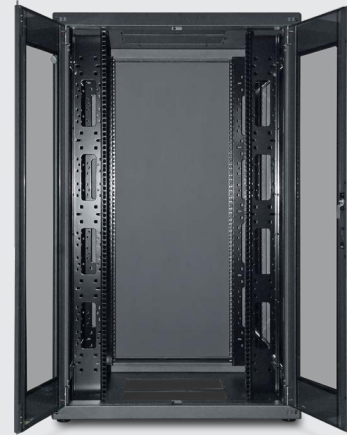

IMAGE® - 27U  
Special version  
with double front doors

# IMAGE® IP30 Primary cabinet

## “PRIMARY” CABINET READY TO USE

The IMAGE® IP30 Primary Kit is a ready configured enclosure, with IP30 environmental protection, pre-equipped with 1 lockable door, a removable rear panel, 2 side panels, top and bottom plain / vented gland plates, front 19" panel mounts, panel mount supports and adjustable feet. It can also be used as the starting point for creating a unique enclosure, by adding additional accessories.

## CONTENTS OF KIT

Description	Qty
Open frame	1
Framed glass / metal front door with lock	1
Removable rear panel	1
Removable side panels	2
Plain top / bottom panels	2
Vented top / bottom panels	2
19" Panel mounting angles	1 pair
19" reducing cable channel (800 mm cabinet width)	1 pair
27U Panel mount support	2 pairs
36U Panel mount support	3 pairs
43U Panel mount support	4 pairs
47U Panel mount support	4 pairs
Adjustable feet	1 kit



IMAGE® IP30 PRIMARY RACK  
Front glass door

# IMAGE® IP30

## Structural elements

### FRAME

The frame includes 4 verticals and 2 end frames.

### PANEL MOUNTING ANGLES

IMAGE® is supplied with 2, 19° panel mounting angles.

### SIDE PANELS

Side panels are supplied with external quarter turn locking, as option it is possible to order a traditional keylock. Side panels are provided of a system that protect from accidental fall during their removal (safety).

### FRONT AND REAR CLOSING

Closing options:

#### Front closing

- Glass door with metal frame (standard) with a single closing point, keyed lock.
- Glass door with metal frame / three point locking, swing handle and European keyed lock cilinder.
- Metal door / single closing point or three point locking, swing handle and European keyed lock.

#### Rear closing

- Removable Panel (standard) triangular key locks supplied
- Metal single door / single closing point or three point locking, swing handle and European keyed lock cilinder.

### SWING HANDLE

Standard doors, with a single closing point, are provided of keyed lock and do not have the swing handle.

For standard doors, both glass and metal, can be ordered as option the swing handle with single point central locking. As a further option can be required European keyed lock cilinder, automatic or manual.

### TOP COVER

This top is provided with two cable entries with panels, a plain one and a vented one. The same top cover can host a thermal kit with two fans, still allowing space for cable entries through optional cover with cable brush or within guillotine system.

### LIFTING EYES

Lifting eyes are sold as a kit of 4 and can be fitted on the upper corners to lift up the cabinet in an easy way. Each lifting eye has a load capacity of 320 Kg.

### BOTTOM

The bottom is provided with two cable entries area with covers, a plain one and a vented one.

### CASTORS KIT

Castors can load up to 115 Kg each under average conditions; fitted to the rack trough the treated holes at the bottom instead of the adjustable feet. Optionally available a plinth to mount feet and castors at the same time.

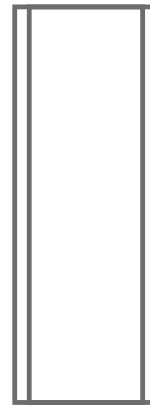

Frame

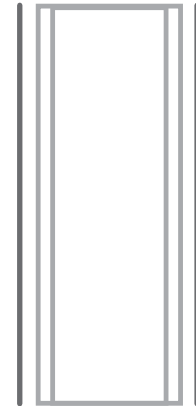

Side panels



Metal door



Glazed door



Bottom

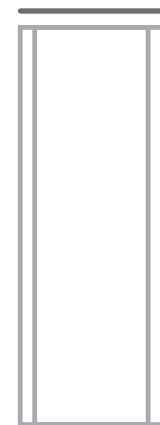

Top cover

# IMAGE® IP30

## Ordering informations

### IMAGE® IP30 PRIMARY KIT GLASS DOOR - STEEL REAR PANEL FRONT PANEL MOUNTING ANGLES

Description	H	W x D	
		600 x 600 mm	600 x 800 mm
Primary Enclosure	27U	<a href="#">VT384-827606</a>	<a href="#">VT384-827608</a>
Additional bay	27U	<a href="#">VT387-827606</a>	<a href="#">VT387-827608</a>
Primary Enclosure	36U	<a href="#">VT384-836606</a>	<a href="#">VT384-836608</a>
Additional bay	36U	<a href="#">VT387-836606</a>	<a href="#">VT387-836608</a>
Primary Enclosure	43U	<a href="#">VT384-843606</a>	<a href="#">VT384-843608</a>
Additional bay	43U	<a href="#">VT387-843606</a>	<a href="#">VT387-843608</a>
Primary Enclosure	47U	<a href="#">VT384-847606</a>	<a href="#">VT384-847608</a>
Additional bay	47U	<a href="#">VT387-847606</a>	<a href="#">VT387-847608</a>

Description	H	W x D	
		600 x 600 mm	600 x 800 mm
Primary Enclosure	27U	<a href="#">VT384-827806</a>	<a href="#">VT384-827808</a>
Additional bay	27U	<a href="#">VT387-827806</a>	<a href="#">VT387-827808</a>
Primary Enclosure	36U	<a href="#">VT384-836806</a>	<a href="#">VT384-836808</a>
Additional bay	36U	<a href="#">VT387-836806</a>	<a href="#">VT387-836808</a>
Primary Enclosure	43U	<a href="#">VT384-843806</a>	<a href="#">VT384-843808</a>
Additional bay	43U	<a href="#">VT387-843806</a>	<a href="#">VT387-843808</a>
Primary Enclosure	47U	<a href="#">VT384-847806</a>	<a href="#">VT384-847808</a>
Additional bay	47U	<a href="#">VT387-847806</a>	<a href="#">VT387-847808</a>



IMAGE® IP30 - Primary Kit  
600 mm width

### IMAGE® IP30 PRIMARY KIT GLASS DOOR - STEEL REAR PANEL FRONT AND REAR PANEL MOUNTING ANGLES

Description	H	W x D	
		600 x 600 mm	600 x 800 mm
Primary Enclosure	27U	<a href="#">VT387-300000</a>	<a href="#">VT387-300003</a>
Primary Enclosure	36U	<a href="#">VT387-300001</a>	<a href="#">VT387-300004</a>
Primary Enclosure	43U	<a href="#">VT387-300002</a>	<a href="#">VT387-300005</a>



IMAGE® IP30 - Primary Kit  
600 mm width



# IMAGE® SERVER

## Introduction

### INTRODUCTION TO IMAGE® SERVER

IMAGE® SERVER is a multi-functional cabinet for server applications. The cabinet frame consists of 2 vertical steel welded frames and top/bottom covers that guarantee a maximum load rate of 1000Kg uniformly distributed. The side panels, easily removable, are provided with external locks and a system that protects from accidental fall during their removal. The 19" panel mounting angles are fixed through side panel mount supports that allow adjustable positioning in the depth of the cabinet. The rear panel mounting angles are split in three zones allowing the installation of multi-vendor servers. The doors, in their available options, are equipped with single central key lock, have a reversible opening and can be equipped with a swing handle. Manual or automatic keyed alike locks are available on request. The top cover is designed to fix a "zero U" ventilation fan tray with 2 or 4 fans (optional).

### KEY FEATURES

- Cabinet structure formed by 2 vertical frames, top and bottom cover
- Side vented top cover provided with 2 cable entry areas with cover plate or alternatively allowing the fixing of 2 or 4 fans "zero U" fan tray
- Adjustable 19" panel mounting angles at the front, adjustable and split at the rear compliant to IEC60297 norms
- 19" side reducing cable channel (800 mm cabinet width) for vertical cable management designed to support cable management accessories
- Easily removable side panels with security external locks
- Reversible front vented door (45%) or glass vented. Single or double vented rear door
- Open bottom to allow an easy entry of the cables or allowing to mount gland plates
- Adjustable feet
- Castors with 250 Kg load rate as optional
- Static load rate of 1000 Kg uniformly distributed
- Additional bay version settled for bayed cabinet
- Designed to mount the earth continuity kit according to EN60950 norms

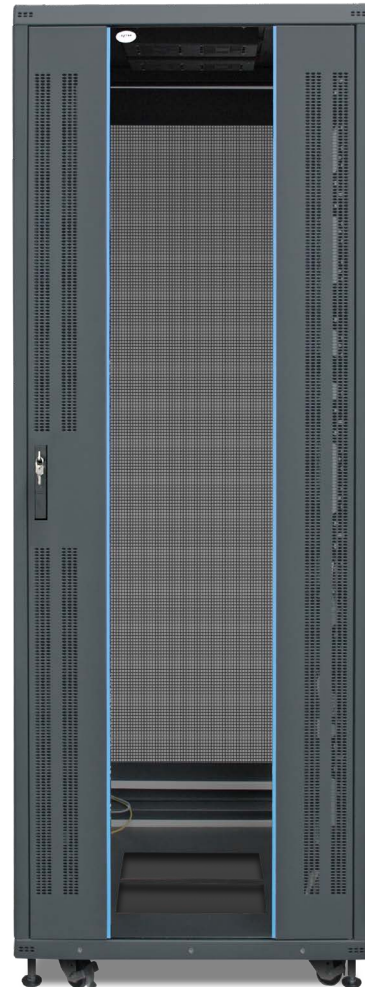

IMAGE® SERVER

# IMAGE SERVER®

## Technical specifications

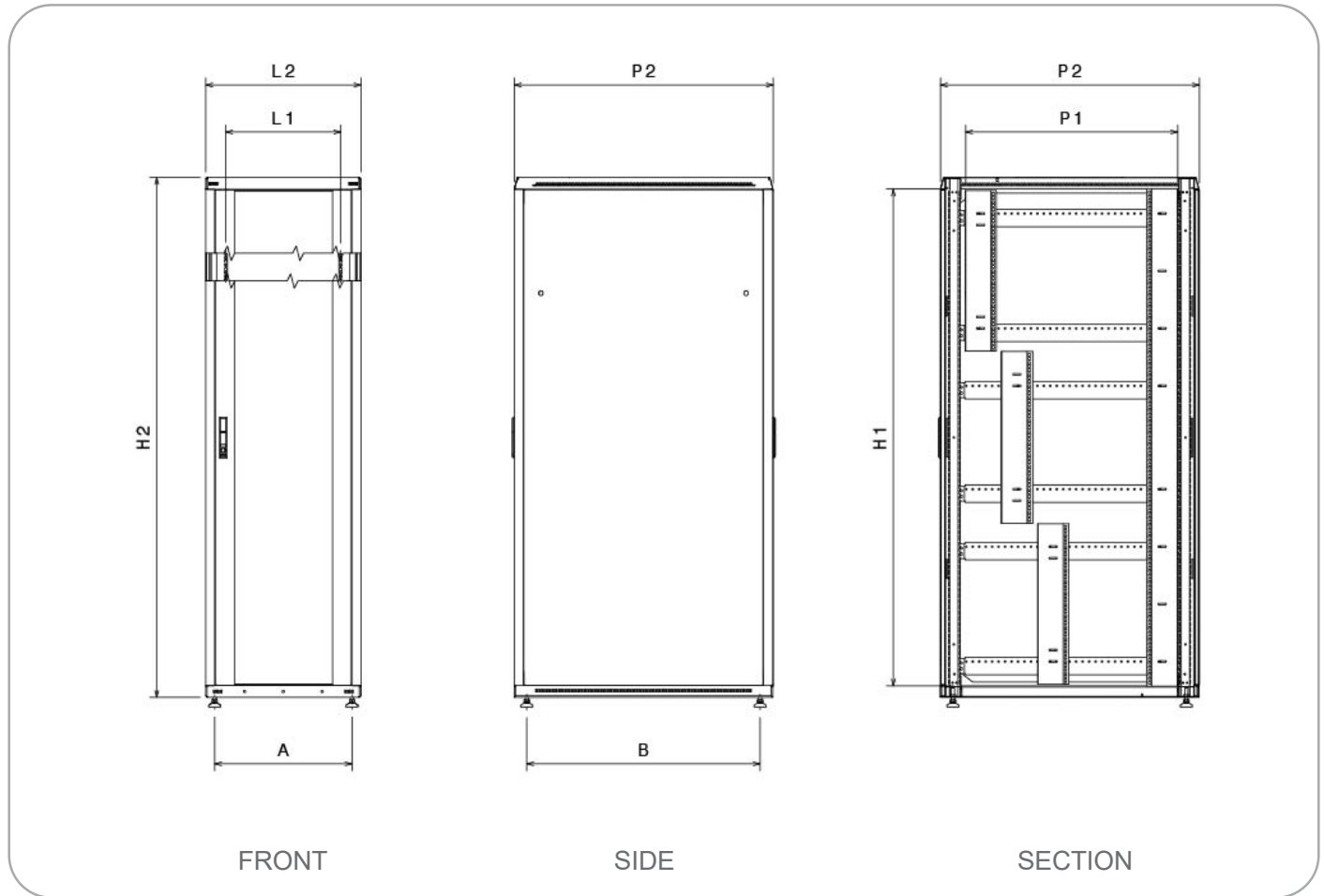

Rack Dimensions	Height		Width		Depth		Feet position	
	H1	H2 (mm)	L1	L2 (mm)	P1 (mm)	P2 (mm)	A (mm)	B (mm)
22U 600 x 600	22U	1078	19"	600	447	600	531	504
22U 600 x 800	22U	1078	19"	600	647	800	531	704
22U 800 x 600	22U	1078	19"	800	447	600	731	504
22U 800 x 800	22U	1078	19"	800	647	800	731	704
27U 600 x 600	27U	1300	19"	600	447	600	531	504
27U 600 x 800	27U	1300	19"	600	647	800	531	704
27U 800 x 600	27U	1300	19"	800	447	600	731	504
27U 800 x 800	27U	1300	19"	800	647	800	731	704
36U 600 x 600	36U	1700	19"	600	447	600	531	504
36U 600 x 800	36U	1700	19"	600	647	800	531	704
36U 800 x 600	36U	1700	19"	800	447	600	731	504
36U 800 x 800	36U	1700	19"	800	647	800	731	704
43U 600 x 600	43U	2011	19"	600	447	600	531	504
43U 600 x 800	43U	2011	19"	600	647	800	531	704
43U 800 x 600	43U	2011	19"	800	447	600	731	504
43U 800 x 800	43U	2011	19"	800	647	800	731	704
47U 600 x 600	47U	2189	19"	600	447	600	531	504
47U 600 x 800	47U	2189	19"	600	647	800	531	704
47U 800 x 600	47U	2189	19"	800	447	600	731	504
47U 800 x 800	47U	2189	19"	800	647	800	731	704

### Additional heights to full height H2:

- Adjustable feet: Minimum 25 mm - Maximum 40 mm
- Castors - 250 Kg static load: 115 mm

# IMAGE SERVER® Primary cabinet

## “PRIMARY” CABINET READY TO USE

The IMAGE® SERVER Primary Kit cabinet is 1000 / 1200 mm deep, to accommodate modern servers and other particularly deep equipment. It is available in 27, 43U or 47U heights and includes the following specification: lockable vented front and rear doors, 2 side panels, top gland plates, front and rear 19” panel mounts, panel mount supports and adjustable feet. The IMAGE® SERVER Primary cabinet can also be used as the starting point for creating a unique enclosure, by adding additional accessories.

The IMAGE® Additional Bay is a ready configured enclosure without side panels but includes 1 baying bracket kit.

## CONTENTS OF KIT

Description	Qty
Open frame	1
Glass vented / fully vented front door	1
Hinged rear vented door	1
Removable side panels	2
Top half cover for plate	2
19” Panel mounts (2 whole and 2 split)	4
19” reducing cable channel, 800 mm cabinet width	2 pairs
27U Panel mount support	2 pairs
43U Panel mount support	6 pairs
47U Panel mount support	6 pairs
Adjustable feet	1 kit

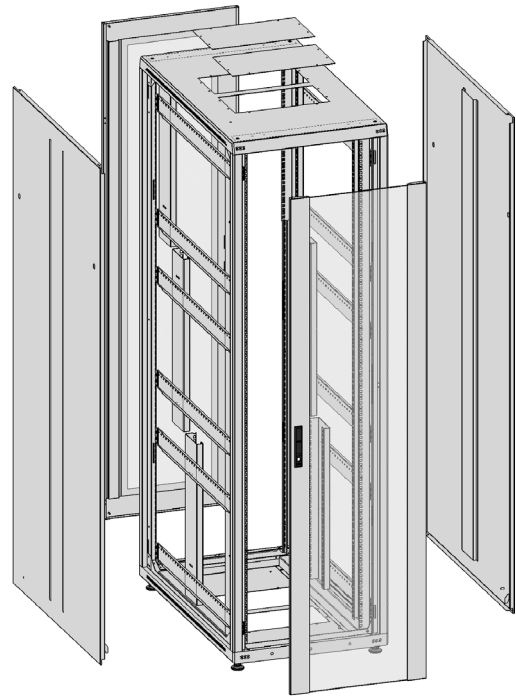

IMAGE® SERVER PRIMARY CABINET  
1000 mm deep

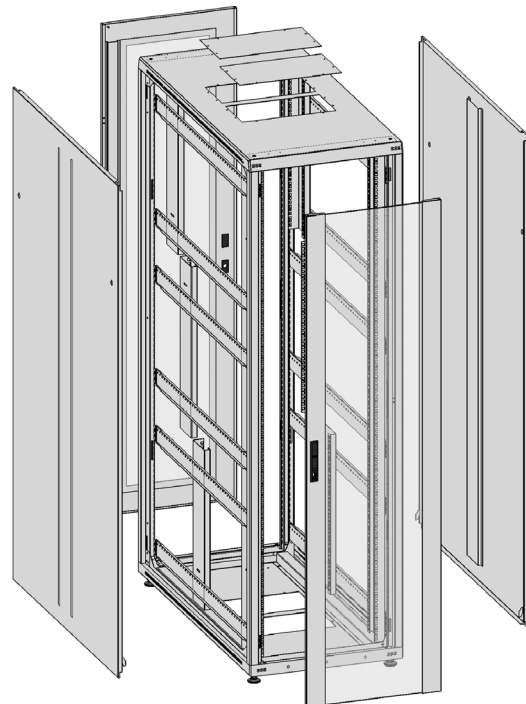

IMAGE® SERVER PRIMARY CABINET  
1200 mm deep

# IMAGE® SERVER

## Ordering informations

### IMAGE® SERVER PRIMARY KIT VENTED GLASS FRONT DOOR VENTED METAL REAR DOOR

Description	H	W x D	
		600x1000 mm	800x1000 mm
Primary Enclosure	27U	<a href="#">VT384-776315*</a>	<a href="#">VT384-776316*</a>
Additional Bay	27U	<a href="#">VT384-776545*</a>	<a href="#">VT384-776546*</a>
Primary Enclosure	43U	<a href="#">VT384-775769</a>	<a href="#">VT384-775770</a>
Additional Bay	43U	<a href="#">VT386-776006</a>	<a href="#">VT386-776007</a>
Primary Enclosure	47U	<a href="#">VT384-775771</a>	<a href="#">VT384-775772</a>
Additional Bay	47U	<a href="#">VT386-776008</a>	<a href="#">VT386-776009</a>

\*Whole 19" rear panel mounting angles

### IMAGE® SERVER PRIMARY KIT VENTED METAL FRONT AND REAR DOORS

Description	H	W x D	
		600x1000 mm	800x1000 mm
Primary Enclosure	27U	<a href="#">VT384-776543*</a>	<a href="#">VT384-776544*</a>
Additional Bay	27U	<a href="#">VT384-776547*</a>	<a href="#">VT384-776548*</a>
Primary Enclosure	43U	<a href="#">VT386-775993</a>	<a href="#">VT386-775994</a>
Additional Bay	43U	<a href="#">VT386-776010</a>	<a href="#">VT386-776011</a>
Primary Enclosure	47U	<a href="#">VT386-775995</a>	<a href="#">VT386-775996</a>
Additional Bay	47U	<a href="#">VT386-776012</a>	<a href="#">VT386-776013</a>

\*Whole 19" rear panel mounting angles

Description	H	W x D	
		600x1200 mm	800x1200 mm
Primary Enclosure	43U	<a href="#">VT386-777413</a>	<a href="#">VT386-777414</a>
Additional Bay	43U	on request	on request
Primary Enclosure	47U	<a href="#">VT386-777415</a>	<a href="#">VT386-777416</a>
Additional Bay	47U	on request	on request



IMAGE® SERVER - Primary Kit  
800 mm width



IMAGE® SERVER - Primary Kit  
800 mm width

# IMAGE<sup>®</sup> SERVER

## Structural elements

### FRAME

The frame includes 4 verticals and 2 end frames.

### PANEL MOUNTING ANGLES

Adjustable 19" panel mounting angles at the front, adjustable and split at the rear compliant to IEC60297 norms.

The 800 mm width includes the reducing channel as standard.

### SIDE PANELS

Side panels are supplied with external quarter turn locking, as option it is possible to order a traditional keylock. Side panels are provided of a system that protect from accidental fall during their removal (safety).

### FRONT AND REAR CLOSING

Closing options:

#### Front closing

- Vented glass door with a single closing point, keyed lock.
- Vented glass door with metal frame / three point locking, swing handle and European keyed lock cilinder.
- Vented double glass door with metal frame, single closing point, keyed lock.
- Metal vented door / single closing point or three point locking, swing handle and European keyed lock cilinder.

#### Rear closing

- Metal vented door / single closing point (standard) or three point locking, swing handle and European keyed lock cilinder.
- Metal vented double door / single point central locking.

### SWING HANDLE

Standard doors, with a single closing point, are provided of keyed lock and do not have the swing handle.

For standard doors, both glass and metal, can be ordered as option the swing handle with single point central locking. As a further option can be required European keyed lock cilinder, automatic or manual.

### VENTED TOP COVER

This top allows convected air to flow out through the sides of the top and is provided with two cable entries with panels. The same top cover can host a thermal kit with two fans, still allowing space for cable entries.

### LIFTING EYES

Lifting eyes are sold as a kit of 4 and can be fitted on the upper corners to lift up the cabinet in an easy way. Each lifting eye has a load capacity of 320 Kg.

### BOTTOM

The bottom is open to offer maximum space for comfortable cable passage.

### CASTORS KIT

Castors can load up to 250 Kg each under average conditions; fitted to the rack with mounting plates. Available in versions with or without brakes.

A plinth to mount feet and wheels at the same time is optionally available.

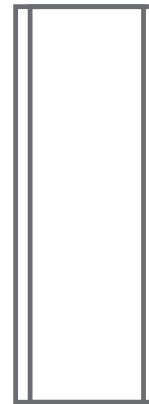

Frame

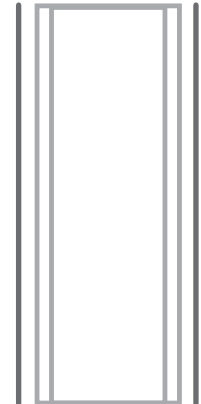

Side panels

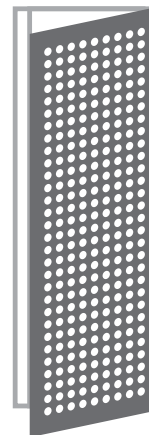

Vented door



Glazed door

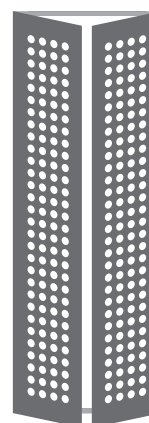

Double door  
front / rear



Top cover

# IMAGE® 21

## Technical specifications

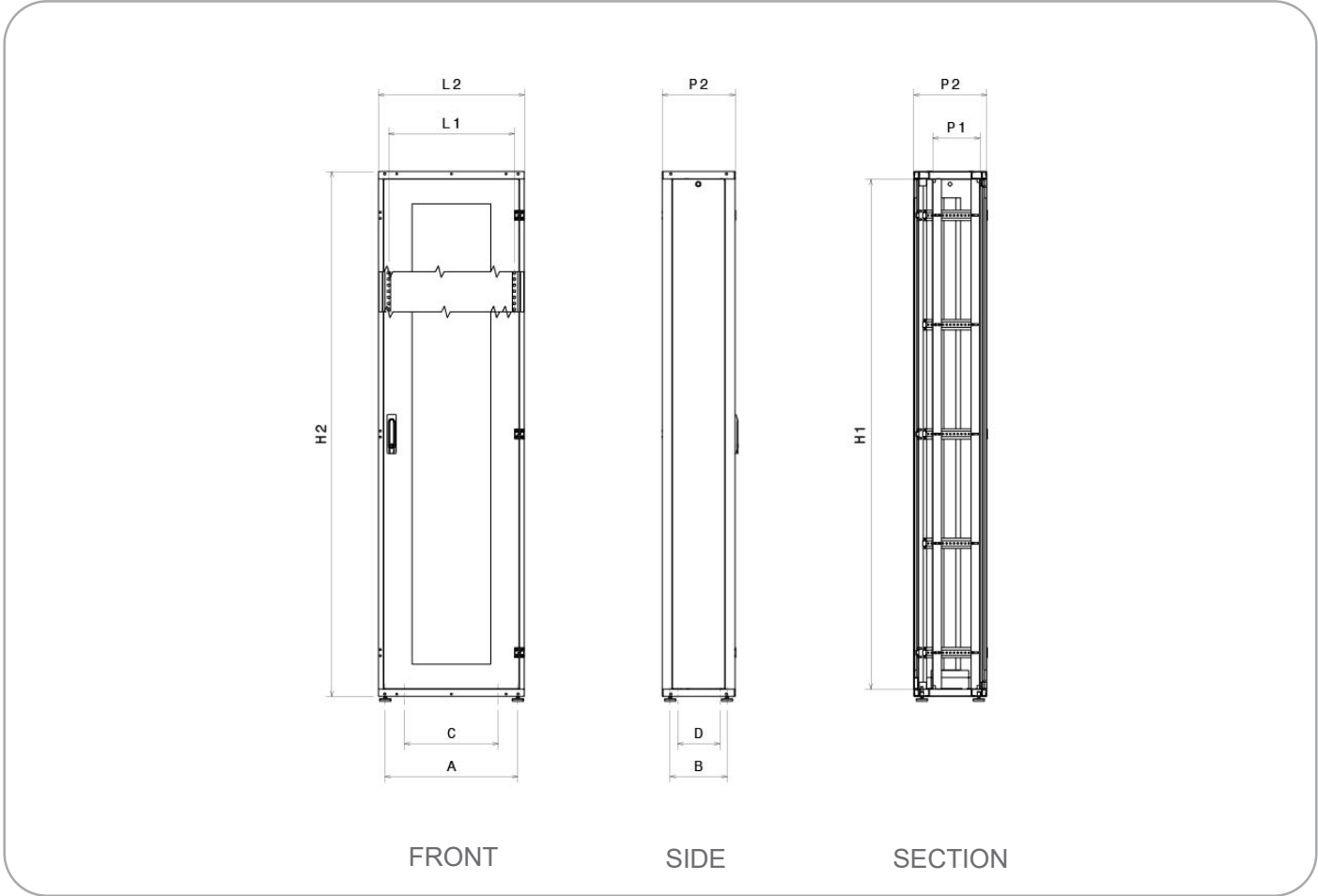

Rack Dimensions	Height		Width		Depth		Feet position		Ground fixing	
	H1	H2 (mm)	L1	L2 (mm)	P1 (mm)	P2 (mm)	A (mm)	B (mm)	C (mm)	D (mm)
47U 600 x 300	47U	2160	21"	600	194	300	546	234	413	194
47U 600 x 600	47U	2160	21"	600	494	600	546	534	413	494

**Additional heights to full height H2:**

- Adjustable feet: Minimum 25 mm - Maximum 40 mm



# IMAGE® 21 Primary cabinet

## “PRIMARY” CABINET READY TO USE

IMAGE® 21 Primary Kit is a specific enclosure for telecommunication applications. The cabinet structure consists of two frames assemblies and two upper / lower covers. IMAGE® 21 is made of steel to ensure a uniform static distribution of 250 Kg. The side panels, easily removable, are provided with external locks. The ETSI / 21” uprights are fastened by side panel mount support that allow adjustable positioning in the cabinet depth. The doors, in their available options, come with central locking, reversible opening and can be equipped with a handle or lock with optional automatic or manual key. The top cover is pre-set for cable entry area, 2 fans fan tray and cabinet for wall fixing. The open bottom for an easy cable entry is pre-set also for floor fixing.

## CONTENTS OF KIT

Description	Qty
Open frame	1
21” Adjustable panel mount support - 600x300 mm version	1 pair
21” Adjustable panel mount support - 600x600 mm version	2 pairs
Front metal vented door	1
Removable rear panel	1
Removable side panels	2
Panel mount support	5 pairs
Top panel	1
Adjustable feet	1 kit

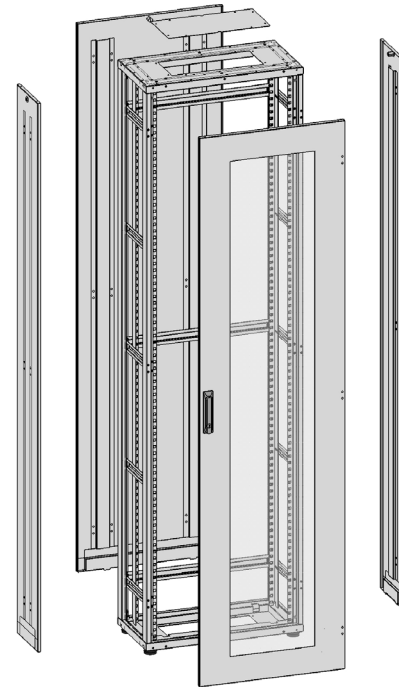

IMAGE® 21 PRIMARY CABINET  
300 mm deep

## ORDERING INFORMATION

H	W	D	Grey RAL 7035	Anthracite RAL 7016
			Order code	Order code
47U	600 mm	300 mm	<a href="#">VT386-200300_7035</a>	<a href="#">VT386-200300_7016</a>
47U	600 mm	600 mm	<a href="#">VT386-200600_7035</a>	<a href="#">VT386-200600_7016</a>

## FLOOR BRACKETS KIT

Description	Order code
Floor brackets kit, 600 mm width	<a href="#">VT385-776504</a>



Floor brackets kit

## SINGLE AND DOUBLE METAL DOORS SINGLE LOCKING POINT

Description	Order code
27U 600 mm steel door	<a href="#">VT385-775557</a>
27U 800 mm steel door	<a href="#">VT385-775623</a>
36U 600 mm steel door	<a href="#">VT385-775558</a>
36U 800 mm steel door	<a href="#">VT385-775624</a>
43U 600 mm steel door	<a href="#">VT385-775559</a>
43U 800 mm steel door	<a href="#">VT385-775625</a>
47U 600 mm steel door	<a href="#">VT385-775897</a>
47U 800 mm steel door	<a href="#">VT385-775898</a>
27U 600 mm double steel door	<a href="#">VT385-776392</a>
27U 800 mm double steel door	<a href="#">VT385-776393</a>
36U 600 mm double steel door	<a href="#">VT385-776394</a>
36U 800 mm double steel door	<a href="#">VT385-776395</a>
43U 600 mm double steel door	<a href="#">VT385-776396</a>
43U 800 mm double steel door	<a href="#">VT385-776397</a>
47U 600 mm double steel door	<a href="#">VT385-776398</a>
47U 800 mm double steel door	<a href="#">VT385-776399</a>

## THREE LOCKING POINTS

Description	Order code
27U 600 mm steel door	<a href="#">VT385-776430</a>
27U 800 mm steel door	<a href="#">VT385-776434</a>
36U 600 mm steel door	<a href="#">VT385-776431</a>
36U 800 mm steel door	<a href="#">VT385-776435</a>
43U 600 mm steel door	<a href="#">VT385-776432</a>
43U 800 mm steel door	<a href="#">VT385-776436</a>
47U 600 mm steel door	<a href="#">VT385-776433</a>
47U 800 mm steel door	<a href="#">VT385-776437</a>

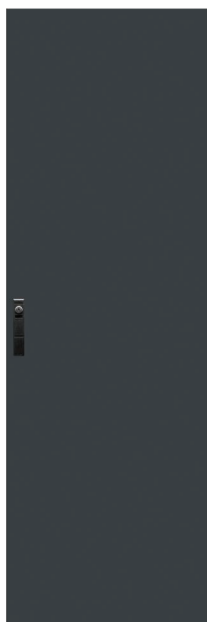

Metal door

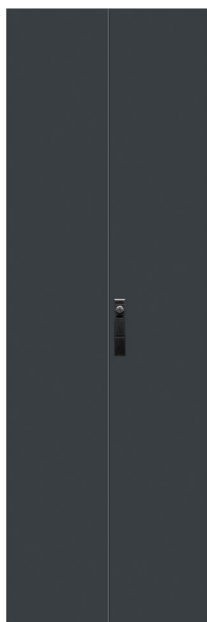

Double metal door

## SINGLE AND DOUBLE VENTED METAL DOORS SINGLE LOCKING POINT

Description	Order code
27U 600 mm vented steel door	<a href="#">VT385-775939</a>
27U 800 mm vented steel door	<a href="#">VT385-776329</a>
36U 600 mm vented steel door	<a href="#">VT385-776207</a>
36U 800 mm vented steel door	<a href="#">VT385-775618</a>
43U 600 mm vented steel door	<a href="#">VT385-775791</a>
43U 800 mm vented steel door	<a href="#">VT385-775801</a>
47U 600 mm vented steel door	<a href="#">VT385-775796</a>
47U 800 mm vented steel door	<a href="#">VT385-775806</a>
27U 600 mm double vented steel door	<a href="#">VT385-776376</a>
27U 800 mm double vented steel door	<a href="#">VT385-776377</a>
36U 600 mm double vented steel door	<a href="#">VT385-776378</a>
36U 800 mm double vented steel door	<a href="#">VT385-776379</a>
43U 600 mm double vented steel door	<a href="#">VT385-776380</a>
43U 800 mm double vented steel door	<a href="#">VT385-776381</a>
47U 600 mm double vented steel door	<a href="#">VT385-776382</a>
47U 800 mm double vented steel door	<a href="#">VT385-776383</a>

## THREE LOCKING POINTS

Description	Order code
27U 600 mm vented steel door	<a href="#">VT385-776462</a>
27U 800 mm vented steel door	<a href="#">VT385-776466</a>
36U 600 mm vented steel door	<a href="#">VT385-776463</a>
36U 800 mm vented steel door	<a href="#">VT385-776467</a>
43U 600 mm vented steel door	<a href="#">VT385-776464</a>
43U 800 mm vented steel door	<a href="#">VT385-776468</a>
47U 600 mm vented steel door	<a href="#">VT385-776465</a>
47U 800 mm vented steel door	<a href="#">VT385-776469</a>

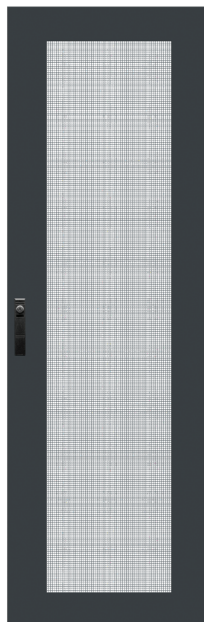

Vented metal door

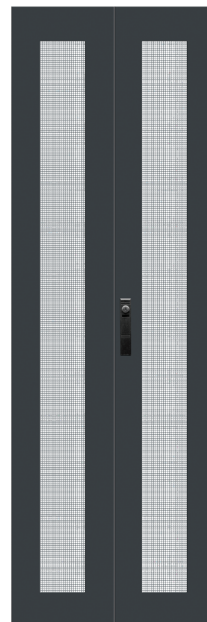

Double vented metal door



## SINGLE AND VENTED GLASS DOORS SINGLE LOCKING POINT

Description	Order code
27U 600 mm glass door	<a href="#">VT385-775389</a>
27U 800 mm glass door	<a href="#">VT385-775392</a>
36U 600 mm glass door	<a href="#">VT385-775390</a>
36U 800 mm glass door	<a href="#">VT385-775393</a>
43U 600 mm glass door	<a href="#">VT385-775391</a>
43U 800 mm glass door	<a href="#">VT385-775394</a>
47U 600 mm glass door	<a href="#">VT385-775759</a>
47U 800 mm glass door	<a href="#">VT385-775760</a>
36U 600 mm glass vented door	<a href="#">VT385-776345</a>
36U 800 mm glass vented door	<a href="#">VT385-776406</a>
43U 600 mm glass vented door	<a href="#">VT385-775787</a>
43U 800 mm glass vented door	<a href="#">VT385-775798</a>
47U 600 mm glass vented door	<a href="#">VT385-775793</a>
47U 800 mm glass vented door	<a href="#">VT385-775803</a>

## SINGLE AND DOUBLE FRAMED GLASS DOORS SINGLE LOCKING POINT

Description	Order code
27U 600 mm glass door with frame	<a href="#">VT388-827600</a>
36U 600 mm glass door with frame	<a href="#">VT388-836600</a>
43U 600 mm glass door with frame	<a href="#">VT388-843600</a>
47U 600 mm glass door with frame	<a href="#">VT388-847600</a>
27U 800 mm glass door with frame	<a href="#">VT388-827800</a>
36U 800 mm glass door with frame	<a href="#">VT388-836800</a>
43U 800 mm glass door with frame	<a href="#">VT388-843800</a>
47U 800 mm glass door with frame	<a href="#">VT388-847800</a>
27U 600 mm double glass door	<a href="#">VT385-776384</a>
27U 800 mm double glass door	<a href="#">VT385-776385</a>
36U 600 mm double glass door	<a href="#">VT385-776386</a>
36U 800 mm double glass door	<a href="#">VT385-776387</a>
43U 600 mm double glass door	<a href="#">VT385-776388</a>
43U 800 mm double glass door	<a href="#">VT385-776389</a>
47U 600 mm double glass door	<a href="#">VT385-776390</a>
47U 800 mm double glass door	<a href="#">VT385-776391</a>

## THREE LOCKING POINTS

Description	Order code
27U 600 mm glass door with frame	<a href="#">VT385-776446</a>
27U 800 mm glass door with frame	<a href="#">VT385-776450</a>
36U 600 mm glass door with frame	<a href="#">VT385-776447</a>
36U 800 mm glass door with frame	<a href="#">VT385-776451</a>
43U 600 mm glass door with frame	<a href="#">VT385-776448</a>
43U 800 mm glass door with frame	<a href="#">VT385-776452</a>
47U 600 mm glass door with frame	<a href="#">VT385-776449</a>
47U 800 mm glass door with frame	<a href="#">VT385-776453</a>



Glass door

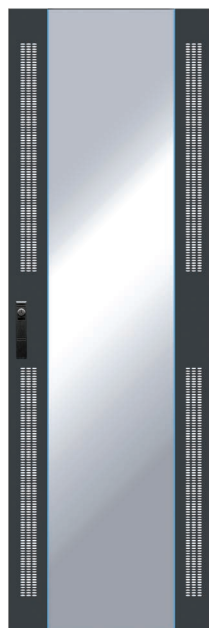

Vented glass door



Framed glass door



Double framed glass door

# IMAGE® Handles & locks

## HANDLES AND LOCKING SYSTEMS

All IMAGE® cabinet models, including server and IP30 versions, adopt the same type of standard closing.

The Primary and Additional Bay configurations, are provided of a key lock with escutcheon plate, without handle.

Other versions, like swing handle with or without locks, are available as optional.

## ORDERING INFORMATION

Description	Order code
Swing handle keyed alike lock - manual locking (2 keys)	<a href="#">VT385-776094</a>
Swing handle keyed alike lock - automatic locking (2 keys)	<a href="#">VT385-776233</a>
Electronic swing handle with mechanical override - single point locking	<a href="#">VA333-301001</a>
Electronic swing handle with mechanical override - three point locking	<a href="#">VA333-301002</a>
Swing handle without lock	<a href="#">VT385-776297</a>
Blank cover	<a href="#">VA802-563534</a>
Swing handle with numeric combination lock and passepertout keys	<a href="#">VA554-546642</a>
Swing handle with badge reader	on request
Swing handle with numeric keypad	on request
Swing handle with dual security system	on request



Standard solution



Swing handle - manual locking



Swing handle with numeric combination



Swing handle with badge reader



Swing handle - automatic locking



Swing handle with numeric keypad



Swing handle with dual security system



Swing handle without lock with blank cover

## THERMAL KIT\*

Description	Order code
Thermal kit 2 fans (half)	<a href="#">VK385-775532</a>
Thermal kit 4 fans (full)	<a href="#">VK385-775828</a>
Thermal kit 2 fans low noise (half)	<a href="#">VK385-775895</a>
Thermal kit 4 fans low noise (full)	<a href="#">VK385-775896</a>
IP30 Thermal kit 2 fans (half)	<a href="#">VK389-775532</a>
IP30 Thermal kit 4 fans (full)	<a href="#">VK389-775828</a>

\*Power cord not included



Thermal kit view inside the cabinet

## THERMOSTAT AND WIRING KIT

Description	Order code
Thermostat and wiring kit	<a href="#">VK385-775843</a>

## ENTRY PANEL KIT

Description	Order code
Brushed cable entry panel top / bottom (half)	<a href="#">VK385-775535</a>
Plain cover top / bottom (half)	<a href="#">VK385-775629</a>
Vented cover top / bottom (half)	<a href="#">VK385-775727</a>
IP30 top/bottom vented plate (half)	<a href="#">VK389-775727</a>

## 19" PANEL MOUNTING ANGLES KIT

Description	Order code
19" 27U front panel mount kit	<a href="#">VK385-775383</a>
19" 36U front panel mount kit	<a href="#">VK385-775384</a>
19" 43U front panel mount kit	<a href="#">VK385-775385</a>
19" 47U front panel mount kit	<a href="#">VK385-775755</a>
19" 27U front panel mount + reducing channels kit 800 mm	<a href="#">VK385-775525</a>
19" 36U front panel mount + reducing channels kit 800 mm	<a href="#">VK385-775526</a>
19" 43U front panel mount + reducing channels kit 800 mm	<a href="#">VK385-775527</a>
19" 47U front panel mount + reducing channels kit 800 mm	<a href="#">VK385-775757</a>

## COVER PLATE FOR REDUCING CABLE CHANNEL KIT

Description	Order code
Blank cover for cable channel IMAGE® quick fix	<a href="#">VT385-776417</a>

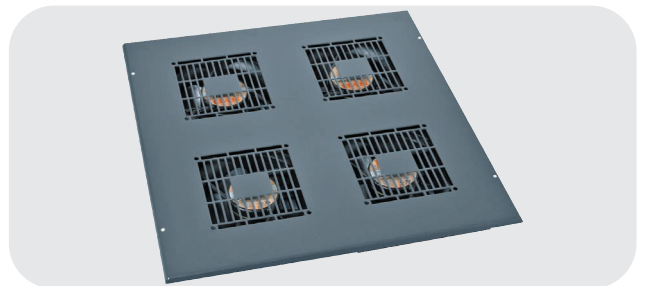

Thermal kit

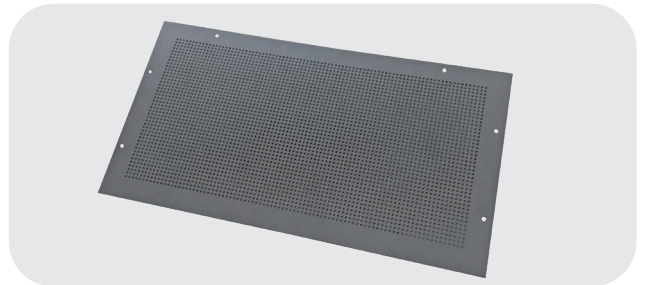

IP30 top/bottom vented plate (half)



Thermostat and wiring kit



19" panel mounting angles kit



Cover plate for reducing cable channel

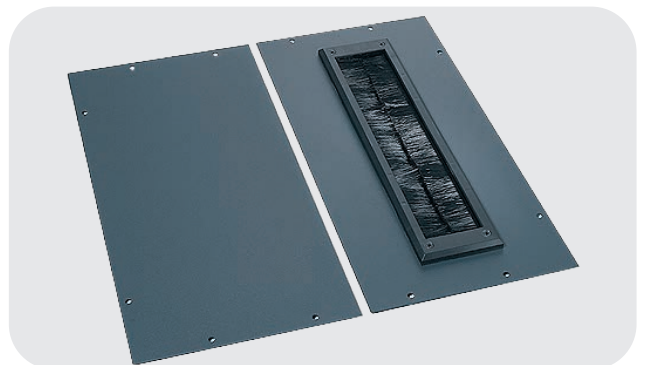

Brushed cable entry panel

# IMAGE® Accessories

## 19" PANEL MOUNT KIT WITH 19" SIDES KIT

Description	Order code
Kit: 2 19" mountings with 47U adapter with 19" sides	on request

## WINDOW CHANNEL MOULDING KIT

Description	Order code
125 mm window channel moulding light blu kit 10 pcs.	<a href="#">VT593-599469</a>
125 mm flag moulding kit 10 pcs.	<a href="#">VT593-599470</a>

## UNIT IDENTIFICATION STRIPS

These self-adhesive strips fit to the cabinet's vertically and simplify the task of positioning panels/equipment accurately on the 'U' spacing. They are supplied in sections to suit racks up to 47U height and are easily cut for other sizes. Available in attractive black finish with silver numeric.

Description	Order code
Unit Identification Strips from 0U to 48U	<a href="#">VA385-775228</a>
Reverse Unit Identification Strips from 48U to 0U	<a href="#">VA385-776542</a>

## PLINTH KIT

Description	Order code
Plinth kit 100 mm 600 x 600 mm	<a href="#">VK385-775505</a>
Plinth kit 100 mm 600 x 800 / 800 x 600 mm	<a href="#">VK385-775506</a>
Plinth kit 100 mm 800 x 800 mm	<a href="#">VK385-775508</a>
Plinth kit 100 mm 600 x 1000 mm	<a href="#">VK385-775847</a>
Plinth kit 100 mm 800 x 1000 mm	<a href="#">VK385-775848</a>
Vented Plinth kit 100 mm 600 x 600 mm	<a href="#">VK385-775933</a>
Vented Plinth kit 100 mm 600 x 800 / 800 x 600 mm	<a href="#">VK385-775934</a>
Vented Plinth kit 100 mm 800 x 800 mm	<a href="#">VK385-775935</a>
Vented Plinth kit 100 mm 600 x 1000 mm	<a href="#">VK385-775928</a>
Vented Plinth kit 100 mm 800 x 1000 mm	<a href="#">VK385-775931</a>
Plinth kit 100 mm for feet and castors 600 x 600 mm	<a href="#">VK385-776498</a>
Plinth kit 100 mm for feet and castors 600 x 800 mm	<a href="#">VK385-776499</a>
Plinth kit 100 mm for feet and castors 600 x 1000 mm	<a href="#">VK385-776500</a>
Plinth kit 100 mm for feet and castors 800 x 600 mm	<a href="#">VK385-776501</a>
Plinth kit 100 mm for feet and castors 800 x 800 mm	<a href="#">VK385-776502</a>
Plinth kit 100 mm for feet and castors 800 x 1000 mm	<a href="#">VK385-776503</a>

## CASTORS AND FEETS KIT

Description	Order code
Light/medium duty castors kit - 80 Kg static load bracked	<a href="#">VK385-775721</a>
Light/medium duty castors kit - 80 Kg static load unbracked	<a href="#">VK385-775722</a>
Heavy duty castors kit - 115 Kg static load 2 bracked	<a href="#">VK385-776250</a>
Heavy duty castors kit - 115 Kg static load 2 unbracked	<a href="#">VK385-776251</a>
Heavy duty castors kit - Server version 250 Kg static load 2 bracked & 2 unbracked	<a href="#">VK385-776541</a>
Heavy duty castors kit - Server version 250 Kg static load 2 bracket & 2 unbracked + feets + adaptors	<a href="#">VK385-776540</a>
Adjustable feet kit	<a href="#">VK385-775653</a>
Foot adaptors kit of 4 for Server version (to assemble feet and castors together)	<a href="#">VK385-776270</a>

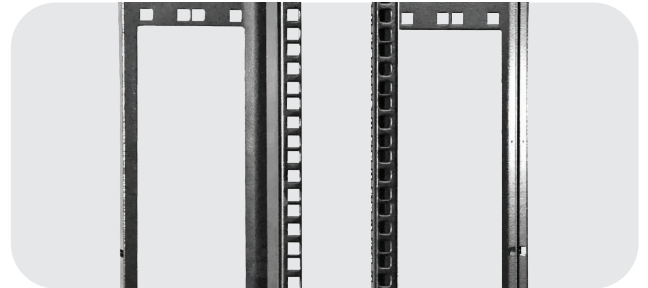

19" panel mount kit with 19" sides

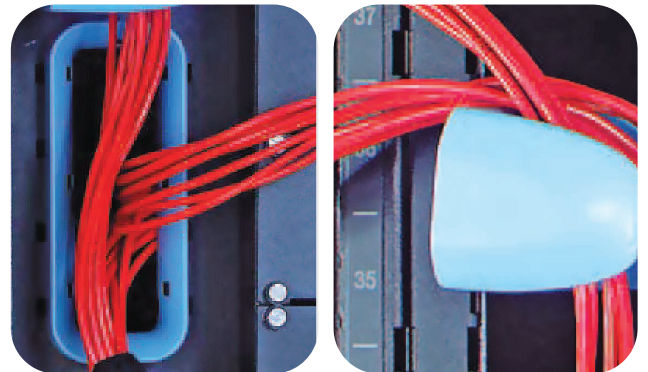

Window channel moulding kit - Flag moulding kit



Unit Identification Strips



Reverse Unit Identification Strips



2 castors kit - 80 Kg static load un/bracked

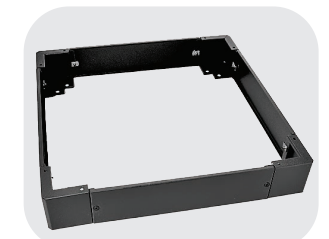

Plinths kit 100 mm



2 castors kit - 115 Kg static load un/braked



250 Kg castors and feets kit



## FIXED SHELF KIT

Load rating 100 Kg

Description	Order code
370 mm deep fixed shelf (600/800 deep version)	<a href="#">VK385-776192</a>
470 mm deep fixed shelf (600/800 deep version)	<a href="#">VK385-775730</a>
570 mm deep fixed shelf (800 deep version)	<a href="#">VK385-776194</a>
670 mm deep fixed shelf (800 deep version)	<a href="#">VK385-775732</a>
670 mm deep fixed shelf (1000 deep version)	<a href="#">VT584-000133</a>
770 mm deep fixed shelf (1000 deep version)	<a href="#">VT584-000134</a>

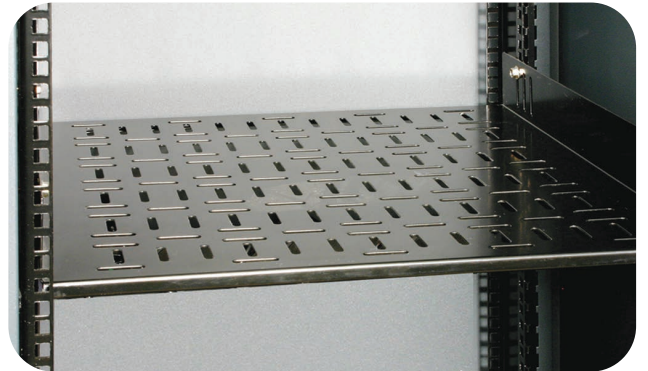

Fixed shelf kit

## ADJUSTABLE FIXED SHELF KIT

Description	Order code
Adjustable fixed shelf (from 550 mm up to 900 mm)	<a href="#">VT584-000366</a>

## SLIDING SHELF KIT

Load rating 35 Kg

Description	Order code
425 mm deep sliding shelf (600/800 deep version)	<a href="#">VK385-776368</a>
625 mm deep sliding shelf (800 deep version)	<a href="#">VK385-776369</a>



Adjustable fixed shelf

## SLIDING SHELF KIT

Load rating 100 Kg

Description	Order code
625 mm deep sliding shelf (1000 deep version)	<a href="#">VT584-000151</a>
825 mm deep sliding shelf (1000 deep version)	<a href="#">VT584-000152</a>

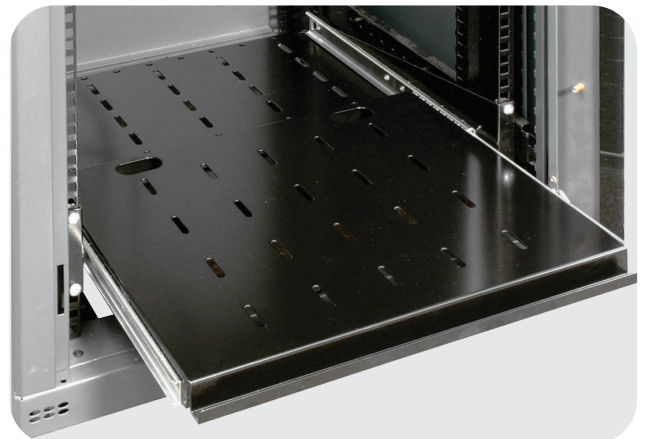

Sliding shelf kit

## 19" CANTILEVER SHELF KIT

Description	Order code
255 mm deep 19" cantilever shelf	<a href="#">VK593-599790</a>
400 mm deep 19" cantilever shelf	<a href="#">VK593-599791</a>

## 19" DIN BAR PANEL KIT

Description	Order code
19" Din bar panel kit RAL 9005	<a href="#">VT390-787644</a>



19" Din bar panel kit

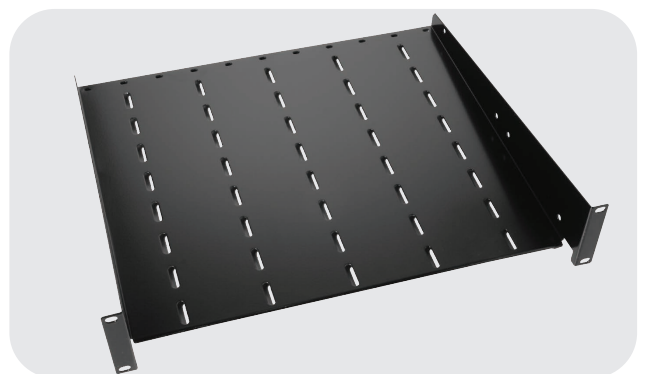

19" cantilever shelf kit

# IMAGE® Accessories

## 19" SLIDING DRAWER KIT

Description	Order code
19" 2U sliding drawer kit RAL 9005	<a href="#">VT390-784799</a>
19" 2U sliding drawer kit RAL 9005 top closed - hidden handle	<a href="#">VT390-788074</a>
19" 2U sliding drawer kit RAL 7035 top closed - hidden handle	<a href="#">VT390-788074_7035</a>
19" 3U sliding drawer kit RAL 9005 top closed - hidden handle	<a href="#">VT390-788091_9005</a>
19" 3U sliding drawer kit RAL 7035 top closed - hidden handle	<a href="#">VT390-788091_7035</a>

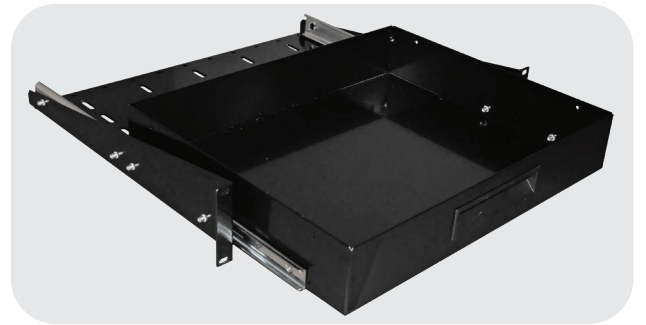

19" sliding drawer kit

## 19" CANTILEVER SLIDING KEYBOARD SHELF KIT

Description	Order code
19" cantilever sliding keyboard shelf	<a href="#">VK385-775709</a>



19" closed sliding drawer with hidden handle kit

## SECURE BOX KIT

Description	Order code
Sensible equipment secure box 2U 19" 600 mm	<a href="#">VT584-000537</a>



19" cantilever sliding keyboard

## CHASSIS SUPPORT KIT

Description	Black RAL 9005	Zinc plated 'conductive'
	Order code	Order code
370 mm chassis support kit (600/800 deep version)	<a href="#">VK385-776268</a>	<a href="#">VT390-787965</a>
470 mm chassis support kit (600/800 deep version)	<a href="#">VK385-775952</a>	<a href="#">VT390-787966</a>
570 mm chassis support kit (800 deep version)	<a href="#">VK385-776252</a>	<a href="#">VT390-787528</a>
670 mm chassis support kit (800 depth version)	<a href="#">VK385-775953</a>	<a href="#">VT390-787537</a>
770 mm chassis support kit (1000 depth version)	<a href="#">VK385-776253</a>	<a href="#">VT390-787967</a>



Secure box

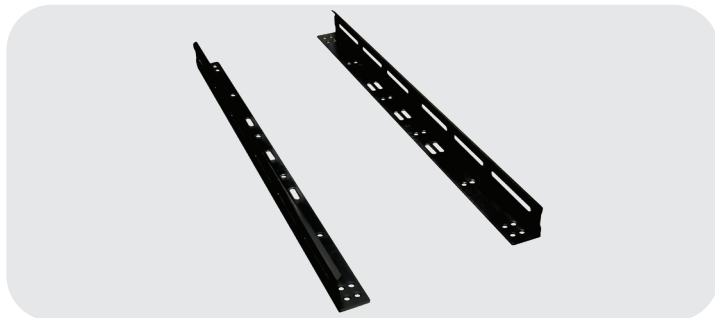

Chassis support black version



Chassis support zinc plated version

## CANTILEVER SUPPORT

Description	Order code
Cantilever support to organize horizontal cables	<a href="#">VT584-000252</a>

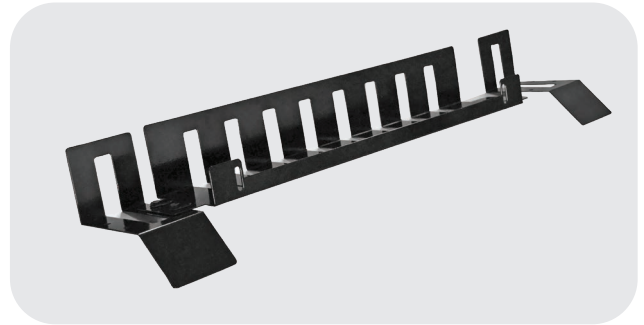

Cantilever Support

## CABLE BAR 19"

Description	Order code
Cable bar 19" black	<a href="#">VK385-776416</a>

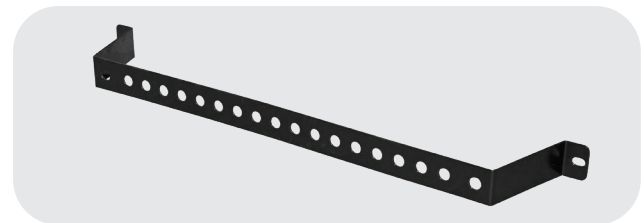

Cable bar 19"

## SINGLE AND DOUBLE CABLE HOOPS KIT

Description	Order code
Double metal cable hoops kit of 10 pcs	<a href="#">VK385-775723</a>
Single plastic cable hoops kit of 10 pcs	<a href="#">VK385-776232</a>

## CABLE MANAGEMENT PANELS KIT

Description	Order code
1U 19" cable management panel w/ metal hoops	<a href="#">VK385-776196</a>
1U 19" cable management panel w/plastic hoops	<a href="#">VK385-776229</a>
Brush strip panel 1U black	<a href="#">VK385-776414</a>
Cable entry panel 2U black	<a href="#">VK385-776413</a>
Black cable management panel 2U	<a href="#">VK385-776415</a>



Single cable metal hoops kit



Single cable plastic hoops kit

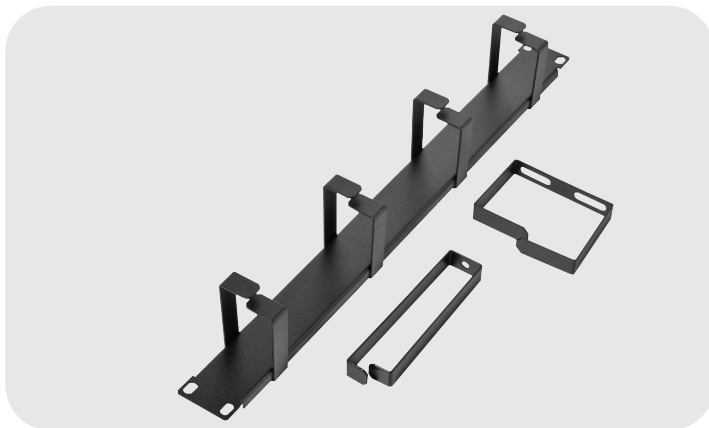

Cable management panels kit



Cable entry panel 2U

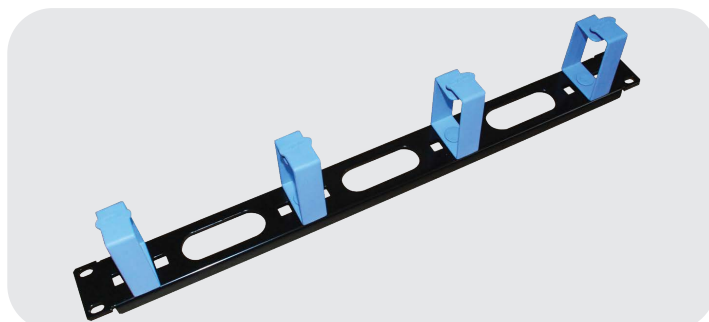

Cable management panel w/ plastic hoops



Cable management panel 2U

# IMAGE® Accessories

## 19" BLANK PANELS

Description	Order code
1U 19" steel blank panel - black (RAL 9005) finishing	<a href="#">VK385-775905</a>
2U 19" steel blank panel - black (RAL 9005) finishing	<a href="#">VK385-775906</a>
3U 19" steel blank panel - black (RAL 9005) finishing	<a href="#">VK385-775907</a>
4U 19" steel blank panel - black (RAL 9005) finishing	<a href="#">VK385-775908</a>
5U 19" steel blank panel - black (RAL 9005) finishing	<a href="#">VK385-775909</a>
1U 19" steel vented panel - black (RAL 9005) finishing	<a href="#">VT555-501531</a>
2U 19" steel vented panel - black (RAL 9005) finishing	<a href="#">VT555-501532</a>
1U Quickfix blank panel kit 100 pcs. - plastic RAL 7016 finishing	<a href="#">VA584-000571</a>



1U 19" steel blank panels

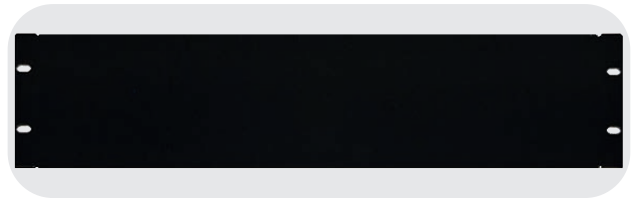

3U 19" steel blank panels

## CABLE MANAGEMENT KIT FOR TOP OF THE CABINET

Description	Order code
Cable tray for rack cover 600 mm wide	<a href="#">VK385-776418</a>
Cable tray for rack cover 800 mm wide	<a href="#">VK385-776419</a>



19" plastic blank panels

## CABLE TRAYS KIT

Description	Order code
Cable tray kit 27U - 180 mm wide	<a href="#">VK385-775713</a>
Cable tray kit 36U - 180 mm wide	<a href="#">VK385-775714</a>
Cable tray kit 43U - 180 mm wide	<a href="#">VK385-775715</a>
Cable tray kit 47U - 180 mm wide	<a href="#">VK385-775850</a>

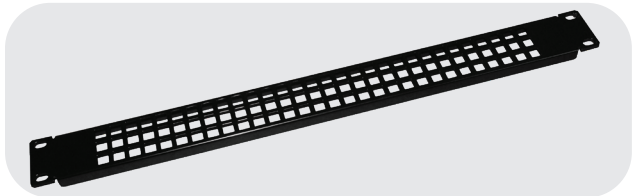

19" steel vented panels



Cable management kit for top of the cabinet



180 mm cable trays kit



## EXTENSION PLINTH KIT

Description	Order code
Extension plinth 600 mm to be used w/castors or plinth only for IMAGE® Server	<a href="#">VK385-775863</a>
Extension plinth 800 mm to be used w/castors or plinth only for IMAGE® Server	<a href="#">VK385-775864</a>
Extension plinth 600 mm to be used w/adjustable feet only for IMAGE® Server	<a href="#">VK385-776214</a>
Extension plinth 800 mm to be used w/adjustable feet only for IMAGE® Server	<a href="#">VK385-776216</a>



Extension plinth

## LIFTING EYES KIT

Description	Order code
Lifting eyes kit - Load capacity 320 Kg x 4	<a href="#">VT385-776187</a>



Lifting eyes kit

## BAYING KIT

Description	Order code
Baying kit	<a href="#">VK385-775545</a>

## DOCUMENT HOLDER

Description	Order code
Document holder A4 size	<a href="#">VT802-553081</a>



Document holder

## MAGNETIC LIGHTS KIT

Description	Order code
Kit LED lamp 400lm w/ magnet fixing, 220V, 5W with ON/OFF switch.	<a href="#">VT802-510011</a>
Kit LED lamp 400lm w/ magnet fixing, 220V, 5W with movement sensor.	<a href="#">VT802-510014</a>
Kit LED lamp 1080lm w/ magnet fixing, 220V, 5W with ON/OFF switch and Schuko plug.	<a href="#">VT802-510026</a>
Kit LED lamp 1080lm w/ magnet fixing, 220V, 5W with ON/OFF switch and UK plug.	<a href="#">VT802-510027</a>

### To be used with:

Description	Order code
Power cord 2mt without termination w/Schuko plug, 10A	<a href="#">VA802-562180</a>
Power cord 2mt without termination w/BS1363/A plug, 13A	<a href="#">VA803-561559</a>



LED kit

# IMAGE® Accessories

## VERTICAL PDU SUPPORT

Description	Order code
Preassembled customized kit PDU with brackets	on request
Preassembled kit PDU with brackets for rack 42U, fixing included	<a href="#">VT390-787968</a>
Preassembled kit PDU with brackets for rack 47U, fixing included	<a href="#">VT390-787969</a>

## CAGED NUTS AND FIXINGS KIT

Description	Order code
M6 caged nuts kit 50 pcs.	<a href="#">VK385-776190</a>
M6 x 12 mm pozzi drive screws and cup washers kit 50 pcs.	<a href="#">VK385-776191</a>

## EARTH CONTINUITY KIT

Description	Order code
Earth continuity kit	<a href="#">VK385-775726</a>
Equipment busbar for cabinets - 1 off	<a href="#">VT802-556088</a>
Earthing bar 13U for cabinets	<a href="#">VT802-552929</a>
Earthing bar 27U for cabinets	<a href="#">VT802-552930</a>
Earthing bar 39U for cabinets	<a href="#">VT802-552931</a>
1U 19" copper earthing bar kit with isolators	<a href="#">VT555-500515</a>



Vertical PDU support

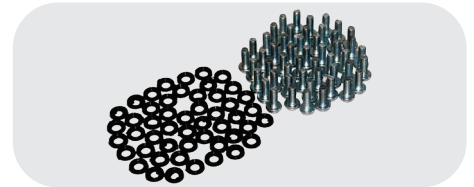

Caged nuts and fixings

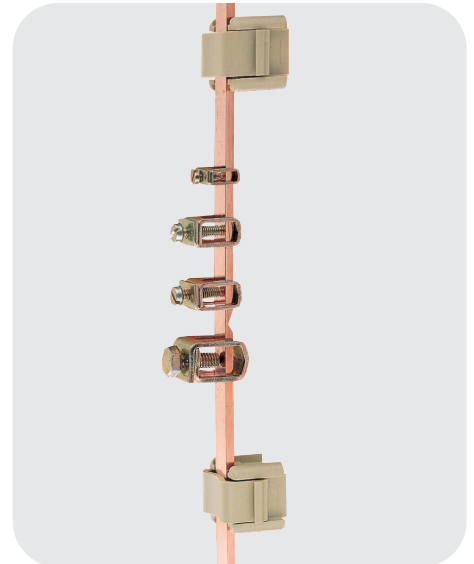

Busbar systems



Earthing bars

# IMAGE® Power distribution unit

## 1U 19" RACKMOUNT MULTISTANDARD ALUMINUM PDU

2 mt cable + plug Schuko

N. sockets	A	Protection	Order code
6	16A	--	<a href="#">C06ALMST-SI2S</a>
6	16A	Illuminated switch	<a href="#">C06ALMST-IL2S</a>
7	16A	MGT 2P+N	<a href="#">C07ALMST-MT2S</a>
8	16A	--	<a href="#">C08ALMST-SI2S</a>
8	16A	Illuminated switch	<a href="#">C08ALMST-IL2S</a>

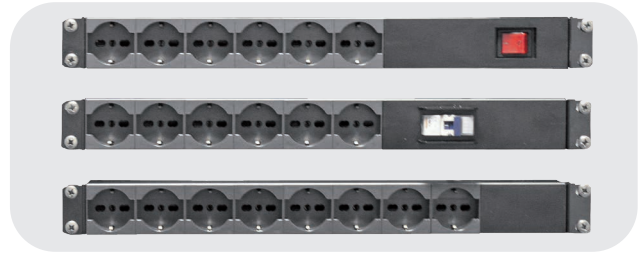

Multistandard aluminum PDU

## 1U 19" RACKMOUNT MULTISTANDARD STEEL PDU

2 mt cable + plug Schuko

N. sockets	A	Protection	Order code
6	16A	--	<a href="#">K06MET-SI2S</a>
6	16A	Illuminated switch	<a href="#">K06MET-IL2S</a>
6	16A	MGT 2P+N	<a href="#">K06MET-MT2S</a>
8	16A	--	<a href="#">K08MET-SI2S</a>
8	16A	Illuminated switch	<a href="#">K08MET-IL2S</a>
9	16A	MGT 2P+N	<a href="#">K09MET-MT2S</a>

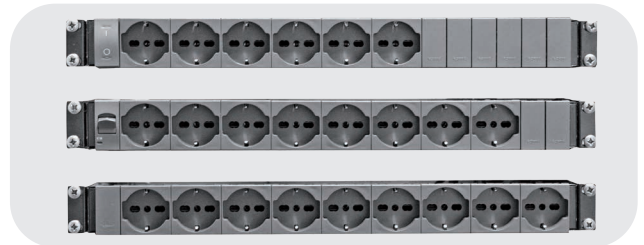

Multistandard steel PDU

## MULTISTANDARD VERTICAL ALUMINUM PDU

2 mt cable + plug Schuko

N. sockets	A	Protection	Order code
12	16A	MGT 2P+N	<a href="#">C12ALMST-MT2S</a>
12	16A	Illuminated switch	<a href="#">C12ALMST-IL2S</a>
16	16A	Illuminated switch	<a href="#">C16ALMST-IL2S</a>
16	16A	MGT 2P+N	<a href="#">C16ALMST-MT2S</a>



Multistandard aluminum vertical PDU

## 1U 19" RACKMOUNT IEC C13 STEEL PDU

2 mt cable + plug Schuko

N. sockets	A	Protection	Order code
8	16A	Illuminated switch	<a href="#">C08MET-16AC13IECIL2S</a>
8	16A	MGT 2P+N	<a href="#">C08MET-16AC13IECMT2S</a>
12	16A	Illuminated switch	<a href="#">C12MET-16AC13IECIL2S</a>



IEC C13 8/12 sockets steel PDU

## 1U 19" RACKMOUNT IEC C13 STEEL PDU

3 mt cable + plug IEC60309

N. sockets	A	Protection	Order code
16	16A	--	<a href="#">K16MET-16AC13IECIND3MT</a>
16	32A	--	<a href="#">K16MET-32AC13IECIND3MT</a>

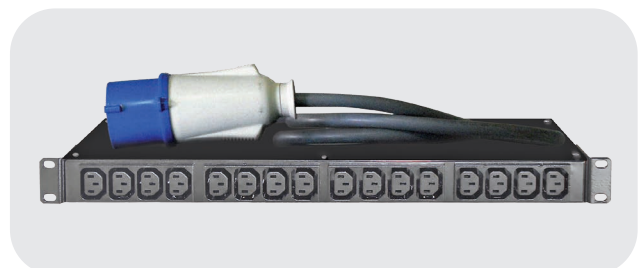

IEC C13 16 sockets steel PDU

# IMAGE®

## Configurations examples



**IMAGE® Application: Datacom**  
IMAGE® 47U 800 x 800 mm with front glass door and on side 19" mounting angles.



**IMAGE® Application: Datacom**  
IMAGE® with side extension cable area.



**IMAGE® Application: Datacom**  
IMAGE® 42U 800 x 1000 mm with "multiclass" reader badge and electrical swing handle on front and rear door for remote access control.



**IMAGE® Application: Datacom**  
IMAGE® 45U 800 x 1000 mm with zinc plated 19" panel mounting and side supports. Front and rear vented door are equipped with swing handle and electric lock managed by a numeric keypad for access control.

# IMAGE® Configurations examples



**IMAGE® Application: Datacom**

Cabinet with double glass door and custom painting.



**IMAGE® Application: Datacom**

IMAGE® with custom front door requested by Customer.



**IMAGE® Application: Datacom**

IMAGE® 47U 600 x 1000 mm with front and rear double vented door to reduce space between cabinet row. The rear 19" panel mounting angles are split in three sections for multi-vendor servers application. The front and rear door have a combination lock for access control.



**IMAGE® Application: Datacom**

IMAGE® 43U 800 x 800 mm with 19" panel mounting angles positioned on one side of the cabinet creating a zone of about 200 mm available to the installation of other non 19" equipment. Front and rear metal doors with swing handle and a three point locking system. The 100mm plinth with removable vented panels mounts caster wheels to facilitate movement of the cabinet on site and leveling feet.



# IMAGE® Configurations examples



## IMAGE® Application: Industry

IMAGE® cabinet divided in three sections: the monitor is hosted in the upper area with glass door, the keyboard is accommodated in the 2U drawer and the 20U bottom section offers a side access sliding shelf for printer and computer.



## IMAGE® Application: Datacom

IMAGE® equipped with sound-absorbing material to reduce the noise generated by the servers for improving the quality of working environment.



## IMAGE® Application: Industry

IMAGE® 27U in 300 mm depth slim execution. Double glass front door with key lock to keep a good visibility of the equipment installed inside the cabinet



## IMAGE® Application: Industry

IMAGE® 43U 600 x 800 mm with the adjustable 19" panel mounting angles assembled on insulators to ensure a completely independent grounding of the equipment from the structure of the cabinet.



**GOMA ELETTRONICA SpA**

Strada Antica di Collegno, 225  
10146 Torino - Italia

Tel: +39 011 7725024

[www.apw.eu.com](http://www.apw.eu.com)

All trademarks are the property of their respective owners  
GOMA ELETTRONICA SpA • P-CTG-EN 1223

Designed by GOMA ELETTRONICA SpA



KEEP IN TOUCH

